

DoubleDimmer-Control

Dimming 2-channel lighting remotely

Compatible with
Yubii[®]
ECOSYSTEM

EN - Instructions and warnings for installation and use

| | |
|---|-----------|
| 1. WARNINGS AND GENERAL PRECAUTIONS | 3 |
| 2. PRODUCT DESCRIPTION | 3 |
| 2.1 - Main features of DoubleDimmer-Control..... | 3 |
| 2.2 - Full compatibility with Z-Wave Plus® devices..... | 3 |
| 3. SPECIFICATIONS | 4 |
| 3.1 - Hardware parameters..... | 4 |
| 3.2 - Power of load..... | 4 |
| 3.3 - Mains voltage..... | 4 |
| 4. INSTALLATION | 5 |
| 4.1 - Safety notes..... | 5 |
| 4.2 - Installation of DoubleDimmer-Control..... | 5 |
| 4.3 - Installation of DoubleDimmer-Control with bypasses..... | 6 |
| 4.4 - Staircase switch connection..... | 6 |
| 5. ADDING DEVICE TO Z-WAVE NETWORK | 7 |
| 5.1 - Adding device to Z-Wave network manually..... | 7 |
| 5.2 - Adding device using SmartStart method..... | 7 |
| 6. DEVICE OPERATION | 8 |
| 6.1 - Controlling DoubleDimmer-Control with PROG-button..... | 8 |
| 6.2 - Resetting DoubleDimmer-Control..... | 8 |
| 6.3 - Button behaviour..... | 8 |
| 7. REMOVING DEVICE FROM Z-WAVE NETWORK | 9 |
| 8. POWER AND ENERGY CONSUMPTION | 10 |
| 9. ASSOCIATIONS | 10 |
| 10. NOTIFICATIONS | 11 |
| 11. CENTRAL SCENES | 12 |
| 12. ADVANCED PARAMETERS | 12 |
| 13. Z-WAVE SPECIFICATION | 14 |
| 14. REGULATIONS | 19 |

1 WARNINGS AND GENERAL PRECAUTIONS

- **Using this product for other purposes than those specified in this manual is strictly forbidden!**
- **All installation and connection operations must be performed exclusively by suitably qualified and skilled personnel with the unit disconnected from the mains power supply.**
- **This manual contains important instructions and warnings for personal safety. Read all parts of this manual carefully. If in doubt, suspend installation immediately and contact Nice Technical Assistance.**
- The product packaging materials need to be disposed of in full compliance with local regulations.
- Never apply modifications to any part of the device. Operations other than those specified may cause malfunctions. The manufacturer declines all liability for damage caused by makeshift modifications to the product.
- Never place the device near sources of heat or expose it to naked flames. These actions can damage the product and cause malfunctions.
- Don't use the product in damp or wet locations, near a bathtub, sink, shower, swimming pool, or anywhere else where water or moisture is present.
- This product isn't intended for use by people (including children) with reduced physical, sensory or mental capabilities or who lack experience and knowledge, unless they are supervised by a person responsible for their safety.
- Make sure children don't play with the product.
- The device is designed to operate within an electrical home installation. Faulty connection or use can result in a fire or electric shock.
- Even when the device is turned off, voltage may be present at its terminals. Any maintenance introducing changes to the configuration of connections or the loads must always be performed with a disconnected fuse.

2 PRODUCT DESCRIPTION

DoubleDimmer-Control is designed to manage two independent light loads, especially those based on LED technology. It's intended for installation in standard wall switch boxes. It can also be installed—according to its technical specifications—wherever it's necessary to control dimmable or non-dimmable lighting circuits.

DoubleDimmer-Control enables control of connected devices either through the Z-Wave® Plus network or a wall switch. It enables switching or dimming two load circuits independently or in parallel.

The device monitors load power consumption, energy consumption, and mains voltage values. This data is sent to the hub through the Z-Wave® network.

2.1 - Main features of DoubleDimmer-Control

- Controlling two light circuits
- Supporting the following device types:
 - » 220–240 V dimmable and non-dimmable LED loads (bulbs)
 - » 12–24 V LED or halogens with dimmable electronic transformers
 - » Dimmable LED drivers (for example, in LED strips)
- Compatible with any Z-Wave® or Z-Wave Plus® hub
- Supporting the protected mode (Z-Wave® network security mode) with AES-128 encryption
- Supporting the SmartStart function
- Possessing advanced microprocessor control
- Sending notifications of load/grid issues
- Remembering the last set lighting level
- Enabling to set your favourite brightness level
- Enabling to set automatic switch-off time
- Working with momentary and toggle types of switches
- Installable in wall switch boxes of suitable dimensions in compliance with applicable regulations
- Measuring active power of the load, energy consumed and voltage of the mains
- Compatible with dimmable LED lights

2.2 - Full compatibility with Z-Wave Plus® devices



This device can be used with all devices accredited with the Z-Wave® Plus certificate and is compatible with such devices produced by other manufacturers. All non-battery operated devices within the network act as repeaters to increase reliability of the network. The device is a Security Enabled Z-Wave® Plus product and a Security Enabled Z-Wave® hub needs to be used to fully utilize the product.

3 SPECIFICATIONS

⚠ The applied load and DoubleDimmer-Control may be damaged if the applied load is inconsistent with the technical specifications.
Don't connect loads greater than those recommended!

3.1 - Hardware parameters

Table 1 - DoubleDimmer-Control - Hardware parameters

| Parameter | Value |
|---|--|
| Power supply voltage range | 220–240 VAC 50/60 Hz |
| Supported device types | <ul style="list-style-type: none"> • 220–240 V dimmable and non-dimmable LED loads • 12–24 V LED or halogens with dimmable electronic transformers • Dimmable LED drivers (for example, in LED strips) |
| Radio protocol | Z-Wave (800 series chip) |
| Radio frequency band | EU: 868.4 MHz, 869.85 MHz AH: 919.8 MHz, 921.4 MHz |
| Max. transmitting power | +6dBm |
| Range | <ul style="list-style-type: none"> • Up to 100 m outdoors • Up to 30 m indoors Depending on the terrain and building structure |
| Leds channel current | 0.3 A |
| Internal power consumption (stady state) | less than 500 mW |
| Internal power consumption (active state) | less than 1 W |
| Overcurrent protection | Each channel |
| Operating temperature | 0–40°C |
| For installation in boxes | Ø = 50 mm, dept ≥ 60 mm |
| Dimensions (Height × Width × Depth) | 45 x 37 x 20 mm |
| Ambient humidity | up to 95% without condensation and agressive gases |
| Ingress Protection class | IP20 |
| Compliance with EU directives | RoHS 2011/65/EU, 2015/863/EU, and RED 2014/53/EU |

Note

- The maximum load rating is 0.3 A per channel, which means a maximum of 70 W for a load with Power Factor = 1 at 230 VAC.
- The device operates on the load using rising edge.
- You can connect both channels of DoubleDimmer-Control with a wire for the device to work as if it had a single channel with a maximum load rating of 0.6 A, which means a maximum of 140 W for a load with power factor = 1 at 230 VAC. Parameter 202 needs to be set to 1 - Outputs connected.

3.2 - Power of load

Measuring the active power of the load connected to the output enables real-time monitoring of the load value. The power is expressed in watts [W].

3.3 - Mains voltage

The device enables real-time monitoring of the mains supply status. The value is given in volts (V).

Note

IEC certification applies in EU countries and most countries using 220–240 V~.

4 INSTALLATION

4.1 - Safety notes

⚠ Danger of electrocution!

- DoubleDimmer-Control is designed to operate within a residential electrical installation. Faulty connection or improper use can result in a fire or electric shock.
- All work on the device needs to be carried out by a qualified, licensed electrician, in accordance with national regulations.
- Even when the device is turned off, voltage may be present at its terminals. Any maintenance involving changes to wiring, to the configuration of connections, or the load must always be performed with the fuse disabled.
- Connecting the device in a manner inconsistent with the manual can cause risk to health, life, or property.

Connect DoubleDimmer-Control in accordance with the following rules:

- Connect only in accordance with one of the diagrams below.
- The device should be installed in a wall switch box that complies with relevant national safety standards and has a minimum depth of 60 mm.
- Electrical switches used in the installation need to comply with applicable safety standards.
- Wires used to connect the control switch shouldn't exceed 100 m in length.

4.2 - Installation of DoubleDimmer-Control

1. Switch off the mains voltage (disable the fuse).
2. Open the wall switch box.
3. Connect the device in accordance with one of the following diagrams.

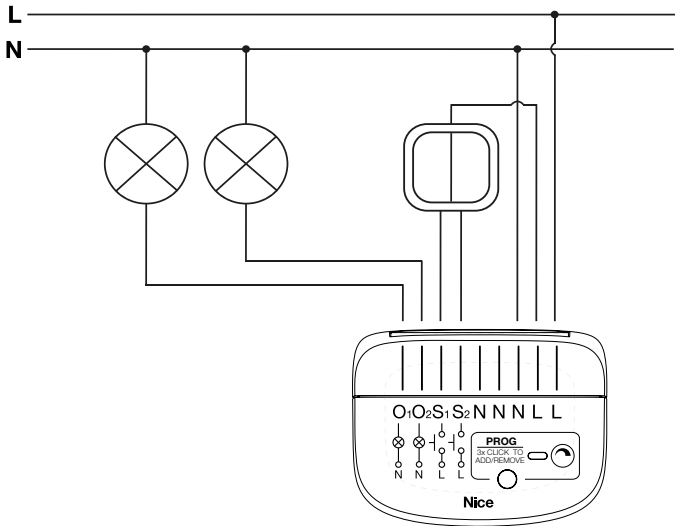

Diagram 1: Double-circuit connection - independent outputs

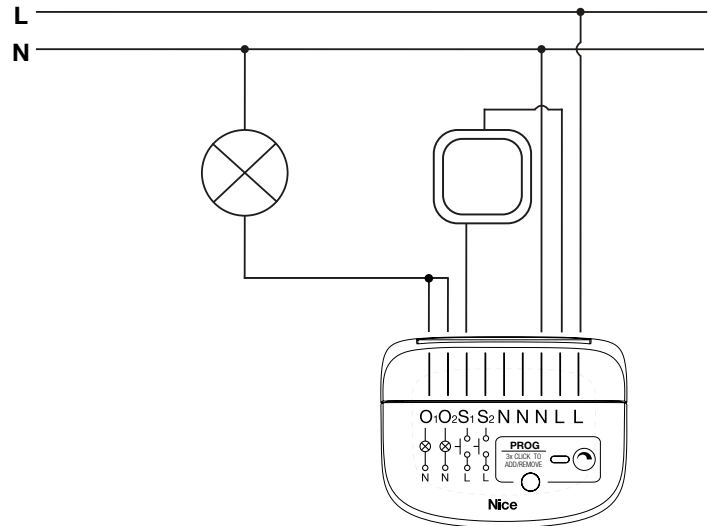

Diagram 2: Single-circuit connection - connected outputs

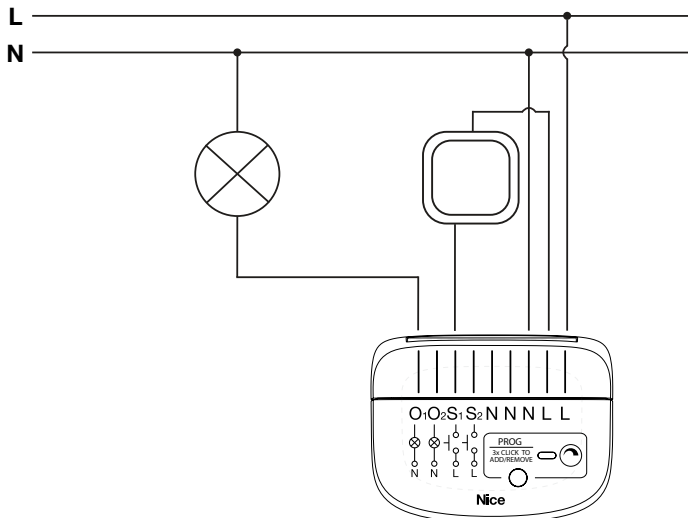

Diagram 3: Single-circuit connection - independent outputs

Notes for the diagrams

- S1** - Terminal for the 1st wall switch
- S2** - Terminal for the 2nd wall switch
- L** - Terminal for the live lead connected internally
- O1** - Output terminal of the 1st channel
- O2** - Output terminal of the 2nd channel
- N** - Terminal for the neutral lead connected internally
- PROG** - Service button (used to add/remove the device and navigate the menu)

4. After verifying the correctness of the connection, switch the mains voltage back on.
5. Add the device to the Z-Wave network.
6. Switch off the mains voltage, then place the device in the wall switch box.
7. Close the wall switch box and switch the mains voltage back on.

- S1 and S2 have the function of activating learning mode. You can activate the learning mode (adding/removing) for 10 minutes after powering on the device.
- By default, the switch connected to S1 terminal turns on/off and dims/brightens the first load, whereas the switch connected to S2 terminal turns on/off and dims/brightens the second load. With parameter 24 Buttons orientation you can change input assignment without the need to change electrical connections
- After switching on the mains voltage, LED indicator signals the Z-Wave network inclusion state with a color:
 - Green** - the device added to the non-secure, S0 or S2 Unauthenticated mode
 - Magenta** - the device added to the S2 Authenticated mode
 - Red** - the device not added

4.3 - Installation of DoubleDimmer-Control with bypasses

NICE LED Adaptor is compatible with NICE DoubleDimmer-Control (FGD-223). We recommend installing LED adaptor when low-power LED bulbs are used. NICE LED Adaptor helps prevent glowing or flickering of lights when they're switched off. You can install one bypass per channel.

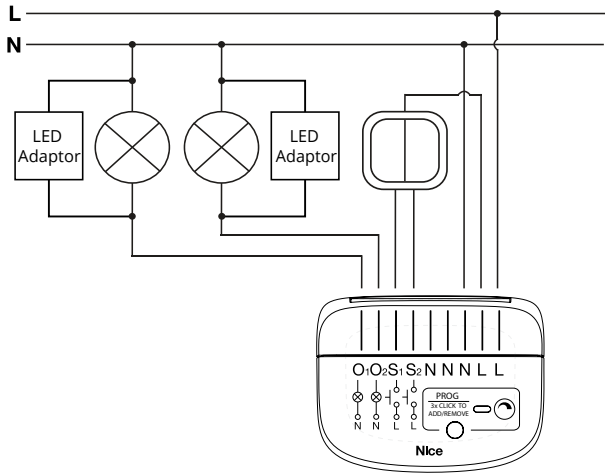

Diagram 4: Double-circuit connection with LED adaptor - independent outputs

4.4 - Staircase switch connection

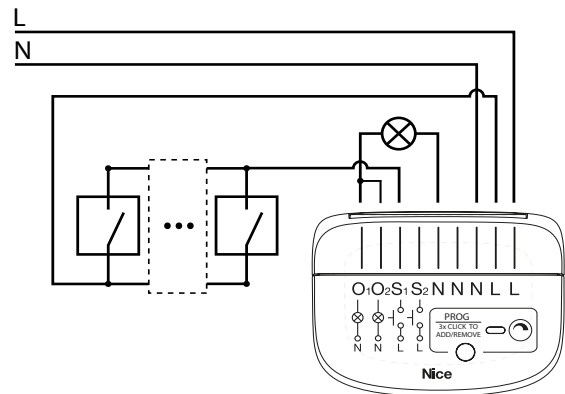

Diagram 5: Momentary switches x1 - connected outputs

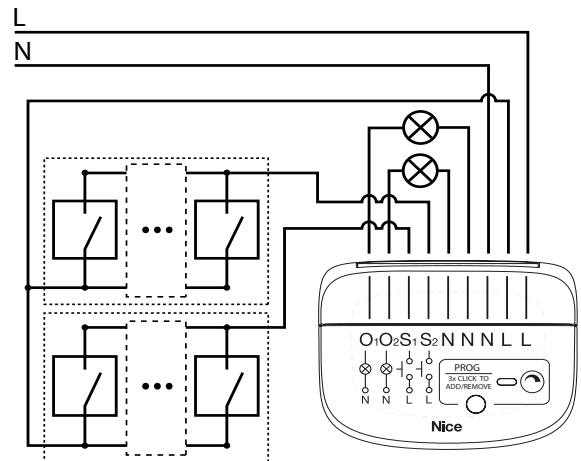

Diagram 6: Momentary switches x2 - independent outputs

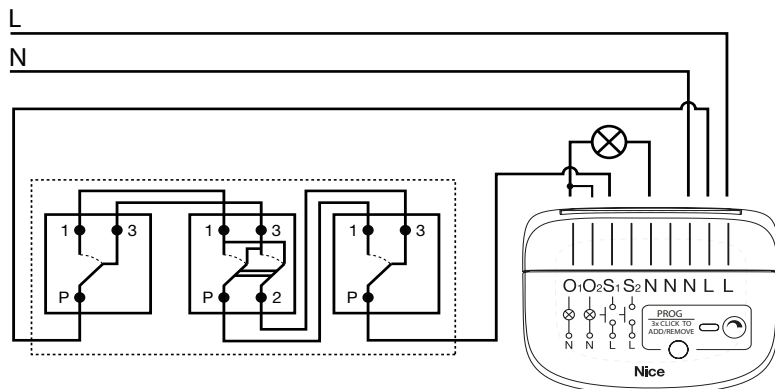

Diagram 7: Stair-cross switches x1 - connected outputs

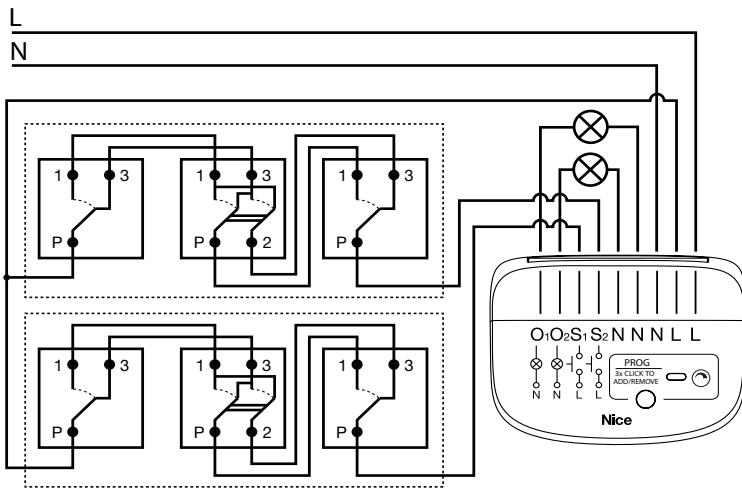

Diagram 8: Stair-cross switches x 2 - independent outputs

5 ADDING DEVICE TO Z-WAVE NETWORK

If you encounter problems adding, removing, or using the wall switches connected to terminals S1 or S2, use the PROG button located on the device housing.

The device tries to add itself after pressing the switch 3 times.

Adding (Inclusion) - The Z-Wave device learning mode enables adding the device to the existing Z-Wave network.

5.1 - Adding the device to the Z-Wave network manually

1. Place DoubleDimmer-Control within the direct range of your Z-Wave hub.
1. Set the main hub to add mode (secure or non-secure). For more information, see the hub manual.
2. Quickly press the S1 or S2 switch, or the PROG button, three times.
3. If you're adding the device in the Security S2 Authenticated mode, input the PIN Code labelled on the device. The PIN Code is also an underlined part of the device specific key (DSK) labelled at the bottom of the box.
4. Wait for the adding process to finish.
5. Successful adding is confirmed by the Z-Wave hub message and the device LED indicator:
 - Green** – successful (non-secure, S0, S2 non-authenticated mode)
 - Magenta** – successful (Security S2 Authenticated mode)
 - Red** – not successful

5.2 - Adding using SmartStart

SmartStart solution enables products to be added into the Z-Wave network by scanning the Z-Wave QR Code present on the product with a hub providing SmartStart inclusion. A SmartStart product is added automatically within 10 minutes of being switched on in the network range.

Note

To use the SmartStart solution, your hub needs to support Security S2 mode. For more information, see the hub manual.

To add the device to the Z-Wave network **using SmartStart**:

1. Enter the full DSK string into your hub. If your hub supports QR scanning, scan the QR code on the label.
2. Power the device by switching on the mains voltage.
3. The LED indicator starts blinking yellow – wait for the adding process to finish.
4. Successful adding is confirmed by the Z-Wave hub message and the device LED indicator:
 - Green** – successful (non-secure, S0, S2 non-authenticated mode)
 - Magenta** – successful (Security S2 Authenticated mode)
 - Red** – not successful

Note

In case of problems with adding the device, reset the device and repeat the adding procedure.

6.1 - Controlling DoubleDimmer-Control with PROG-button

DoubleDimmer-Control is equipped with the PROG-button, which enables using the menu and performing actions listed in the table below.

| Action | Result |
|-----------------|---|
| 1x click | <ul style="list-style-type: none"> Select a desired menu position (if the menu is active) Turn on/off both channels (the 1st and 2nd) |
| 3x click | Send the Node Info Z-Wave command frame (adding/removing) |
| Hold | Enter the menu |

6.2 - Resetting DoubleDimmer-Control

1. Switch off the mains voltage (disable the fuse).
2. Remove DoubleDimmer-Control from the wall switch box.
3. Switch on the mains voltage.
4. Press and hold the PROG-button to enter the menu.
5. Wait for the visual LED indicator to glow yellow (Position 1).
6. Quickly release and click the PROG-button again.
7. After a few seconds, the device restarts, which is indicated by the red LED indicator.

6.3 - Button behaviour

By default, the device is set to operate on a monostable switch. If you connected bistable buttons, make sure to use the double-triple click from OFF state. To confirm that press the button once and check if the output turns on. If yes, the button is now in the ON state.

| Button type | Action | Result |
|--|--------------|--|
| Single monostable switch connected to S1 terminal | Single click | Turns both outputs on/off depending on the status of output O1 |
| | Double click | Sets the status of outputs O1, O2 according to parameters 164/165 |
| | Triple click | Goes into the learn mode within 10 minutes after the device activation |
| | Hold | Brightens/dims both outputs in the range of 1–99% |
| Single monostable switch connected to S2 terminal | Single click | Turns both outputs on/off depending on the status of output O2 |
| | Double click | Sets the status of outputs O1, O2 according to parameters 164/165 |
| | Triple click | Goes into the learn mode within 10 minutes after the device activation |
| | Hold | Brightens/dims both outputs in the range of 1–99% |
| Double monostable switch | Single click | Turns on/off the output assigned to button S1->O1, S2->O2 |
| | Double click | Sets the status of the output according to parameters 164/165 |
| | Triple click | Goes into the learn mode within 10 minutes after the device activation |
| | Hold | Brightens/dims the outputs in the range of 1–99% |
| Single bistable button (closed contacts – on, open contacts – off) connected to S1 terminal | Single click | Turns both outputs on/off depending on the status of output O1 |
| | Double click | Sets the status of the outputs according to parameters 164/165 |
| | Triple click | Goes into the learn mode within 10 minutes after the device activation |
| Single bistable button (closed contacts – on, open contacts – off) connected to S2 terminal | Single click | Turns both outputs on/off depending on the status of output O2 |
| | Double click | Sets the status of the outputs according to parameters 164/165 |
| | Triple click | Goes into the learn mode within 10 minutes after the device activation |
| Double bistable switch (normally open – on, normally closed – off) | Single click | Turns on/off the output assigned to button S1->O1, S2->O2 |
| | Double click | Sets the status of the outputs according to parameters 164/165 |
| | Triple click | Goes into the learn mode within 10 minutes after the device activation |
| Single bistable button connected to S1 terminal - the device changes state with each change of the switch state | Single click | Turns both outputs on/off depending on the status of output O1 |
| | Double click | Sets the status of the outputs according to parameters 164/165 |
| | Triple click | Goes into the learn mode within 10 minutes after the device activation |

Table 3 - DoubleDimmer-Control - Button behaviour

| Button type | Action | Result |
|--|---|--|
| Single bistable button connected to S2 terminal - the device changes state with each change of the switch state | Single click | Turns both outputs on/off depending on the status of output O2 |
| | Double click | Sets the status of outputs O1, O2 according to parameters 164/165 |
| | Triple click | Goes into the learn mode within 10 minutes after the device activation |
| Double bistable button - the device changes state with each change of the switch state | Single click | Turns on/off the output assigned to button S1->O1 S2->O2 |
| | Double click | Sets the status of the output according to parameters 164/165 |
| | Triple click | Goes into the learn mode within 10 minutes after the device activation |
| Automatic detection | Within 10 minutes, press the buttons connected to S1 and S2 so that the device can identify the type of button connected. | |
| No button | Operations blocked on S1/S2 | |

Table 4 - DoubleDimmer-Control - Connected outputs vs. single switch

| Single switch | Parameter 202 set to 1 - Connected outputs |
|---|--|
| <ul style="list-style-type: none"> • Outputs can't be bridged • Possible to set two different values for the outputs O1 and O2 • Possibility of switching on/off a single output from the radio • Possibility to set different parameters values for each channel | <ul style="list-style-type: none"> • Outputs can be bridged • Impossible to set different values for the outputs • Both outputs controlled simultaneously by a radio command (impossible to operate only one output) • Both channels use the parameter setting from the first channel. |

Note
If you turn off the double-click and central scene, the device doesn't wait additional time for another press.

7 REMOVING DEVICE FROM Z-WAVE NETWORK

You can remove the device from the Z-Wave network using switches (S1 or S2) for 10 minutes after powering the device.

Removing (Exclusion) - The Z-Wave device remove mode enables removing the device from the existing Z-Wave network.

To remove the device from the Z-Wave network:

1. Place DoubleDimmer-Control within the direct range of your Z-Wave hub.
2. Set the main hub to the remove mode. For more information, see the hub manual.
3. Quickly press S1 or S2 switch, or the PROG button, three times.

Note

This function for S1 and S2 switches is available for 10 minutes after powering the device.

4. Wait for the removing process to end.
5. Successful removal is confirmed by the Z-Wave hub message and the red LED indicator.

8 POWER AND ENERGY CONSUMPTION

- DoubleDimmer-Control requires the connected load to have a power consumption of 5 W or more to correctly measure power and energy.
- Voltage measurement can reflect mains voltage fluctuations within +/- 10%.
- DoubleDimmer-Control measures power and consumed energy separately for each channel. Disconnecting the module from the power supply doesn't erase stored energy consumption data.

The power value is sent to the main Z-Wave hub

- every hour.
- if the current power differs by more than 20% from the value sent in the previous report.

The consumed energy value is sent to the main Z-Wave hub and saved in the device memory every hour.

The most advanced micro-controller technology carries out the measuring, ensuring maximum accuracy and precision (+/- 5%) for loads greater than 5 W.

Electric active power - the power that an energy receiver converts into work or heat. The unit of active power is watt [W].

Electric energy - the energy consumed by a connected load over a period of time. Electricity consumers are charged on the basis of active power used during a given unit of time, which is most commonly measured in kilowatt-hours [kWh]. One kilowatt-hour equals one kilowatt of power consumed over one hour: 1 kWh = 1000 Wh.

9 ASSOCIATIONS

Association (linking devices) - Direct control of other devices within the Z-Wave network using the wall switch connected to DoubleDimmer-Control. The association enables DoubleDimmer-Control to control devices directly included in the Z-Wave network such as dimmers, switches, or roller shutters. Associations ensure the direct transfer of control commands between devices, which is performed without the involvement of the main hub and requiring the associated device to be within direct range.

DoubleDimmer-Control supports the operation of multichannel devices, which contain two or more circuits within a single physical unit.

DoubleDimmer-Control supports five association groups, listed in the table below.

Table 5 - DoubleDimmer-Control - Association groups

| Association group | Group name | Description | Usage |
|-------------------|------------|---|-------------------------------|
| 1 st | Lifeline | Reports the device status | Main hub by default |
| 2 nd | On/Off S1 | Assigned to switch connected to S1 terminal | Uses Basic command class |
| 3 rd | Dimmer S1 | Assigned to switch connected to S1 terminal | Uses Multilevel command class |
| 4 th | On/Off S2 | Assigned to switch connected to S2 terminal | Uses Basic command class |
| 5 th | Dimmer S2 | Assigned to switch connected to S2 terminal | Uses Multilevel command class |

DoubleDimmer-Control enables control of up to five regular or multichannel devices per group in association groups 2 to 5. The Lifeline group is reserved solely for the hub, so only one node can be assigned to it.

When the auto-off mode is enabled on one of the endpoints, and the auto-off time elapses, no association command is sent, with the exception of the Lifeline group.

Table 6 - DoubleDimmer-Control - Notifications

| Event | Device actions after detecting event | Hub reactions after detecting event | Device actions after event cancellation |
|-------------------------------------|--|---|---|
| Overheat | <ul style="list-style-type: none"> Both channels are turned off. Local and RF control are ignored until the temperature decreases. An overheat notification is sent to the system. | Notifies the user about the event by sending an email. | The notification of overheat cancellation is sent to the system. |
| Load error - burnt-out bulb | <ul style="list-style-type: none"> The load error notification is sent to the system. The device remains on and continues to send Central Scene commands and association messages. | Notifies the user with an email or a push message that the device detected a problem with the connected load. The user needs to make sure that the load complies with the device technical specifications, is correctly connected, and is in proper working order. | The occurrence of the error isn't stored in the device memory and no cancellation message is sent. |
| Load error on control output | <ul style="list-style-type: none"> System [0x09], System hardware failure (manufacturer proprietary failure code provided) 0x03, Manufacturer specific code 0x07 notifications are sent to the system. The device remains on and continues to send Central Scene commands and association messages. Parameters 160 and 161 are set to 1- dimming not available. | Notifies the user with an email or a push message that the device has detected a problem with the connected load. The load is likely non-dimmable. The device has been switched to the On/Off control mode. | — |
| Overcurrent | <ul style="list-style-type: none"> The overcurrent notification is sent to the system. If channels are connected, the notification is sent on the first channel and the device is turned off. If channels aren't connected, the notification is sent on the channel where the overcurrent was detected and that channel is turned off. Output control from the local keys and RF is blocked. The device enables operation after 1 minute. | Notifies the user with an email that the device has detected overcurrent condition and the connected load has been turned off. The user needs to make sure that the load complies with the device technical specifications, is correctly connected, and is in proper working order. | The notification of cancellation is sent after 1 min. |
| Voltage drop | The voltage drop notification is sent to the system. | Notifies the user with an email or push message that a loss of mains power was detected and the device has been turned off. The user should check their network. | Returns to operation according to the settings for post-power outage behavior. |
| Overvoltage | <ul style="list-style-type: none"> The overvoltage notification is sent to the system. The device continues to operate normally. | Notifies the user about the event by sending an email or push message. The user should check their network. | The notification of cancellation is sent when the voltage is 10 V lower than the set limit for at least 10 minutes. |
| Hardware fail | <ul style="list-style-type: none"> Both channels are turned off. Local and RF control aren't available. The hardware failure notification is sent to the system. | Sends an email or push message notifying the user about the event and requesting a power reset. If the issue persists, the user should contact the technical support department. | Returns to operation according to the settings for post-power outage behavior. |

11 CENTRAL SCENES

DoubleDimmer-Control can activate scenes in the hub by sending a scene ID and an action attribute using the Central Scene Command Class. You can configure Central Scenes with parameters 40 and 41.

Table 7 - DoubleDimmer-Control - Activating scenes

| Terminal | Action | Scene ID | Attribute |
|---------------------------------|-----------------------|----------|---------------------|
| Switch connected to S1 terminal | Switch clicked once | 1 | Key Pressed 1 time |
| | Switch clicked twice | | Key Pressed 2 times |
| | Switch clicked thrice | | Key Pressed 3 times |
| | Switch held | | Key Held Down |
| | Switch released | | Key Released |
| Switch connected to S2 terminal | Switch clicked once | 2 | Key Pressed 1 time |
| | Switch clicked twice | | Key Pressed 2 times |
| | Switch clicked thrice | | Key Pressed 3 times |
| | Switch held | | Key Held Down |
| | Switch released | | Key Released |

12 ADVANCED PARAMETERS

DoubleDimmer-Control enables customization of its operation to suit the user's needs. The settings are available through the interface of the Z-Wave hub. Parameters available for DoubleDimmer-Control are listed in the table below.

Table 8 - DoubleDimmer-Control - Advanced parameters

| Parameter | Description | Available setting | Default setting | Length |
|---|--|--|-----------------|--------|
| 1 [0x01] Restore state after power failure | Determines whether the device returns to its previous state after a power failure once power is restored. | <ul style="list-style-type: none"> • 0 - The device doesn't save the state prior to the power failure and returns to „off” position. • 1 - The device restores its state prior to the power failure. | 1 | 1B |
| 20 [0x14] Switch type | Defines the type of switch the device should treat as connected to the S1 and S2 terminals. After selecting auto-detection, you need to operate the wall switch within 10 minutes. | <ul style="list-style-type: none"> • 0 - Momentary switch (single) • 1 - Momentary switch (double) • 2 - Toggle switch (contact closed = ON, contact opened = OFF) - single • 3 - Toggle switch (contact closed = ON, contact opened = OFF) - double • 4 - Toggle switch (the output changes state whenever the switch changes state) - single • 5 - Toggle switch (the output changes state whenever the switch changes state) - double • 6 - Auto-detection • 7 - None | 1 | 1B |
| 24 [0x18] Buttons orientation | Enables changing input assignments without the need to modify electrical connections. | <ul style="list-style-type: none"> • 0 - Normal orientation • 1 - Inverted orientation | 0 | 1B |
| 40 [0x28] First button - scenes sent | Determines which actions trigger sending the scene IDs assigned to them. Values can be combined. For example, 1 + 2 = 3 means that scenes for single and double clicks are sent. | Range: 0...15 (bitmask) <ul style="list-style-type: none"> • 0 - no scenes • 1 - Key pressed 1 time • 2 - Key pressed 2 times • 4 - Key pressed 3 times • 8 - Key hold down and released | 15 | 1B |
| 41 [0x29] Second button - scenes sent | | | | |
| 154 [0x9A] First channel - auto off | Enables setting the auto-off time for the first channel. If set to “0”, the functionality is disabled. | Range: 0...43200 <ul style="list-style-type: none"> • 0 - Auto off disabled • 1...43 200 (0x0001...0xA8C0) [s]- Auto off time | 0 | 2B |
| 155 [0x9B] Second channel - auto off | Enables setting the auto-off time for the second channel. If set to “0”, the functionality is disabled. | | | |

Table 8 - DoubleDimmer-Control - Advanced parameters

| Parameter | Description | Available setting | Default setting | Length |
|---|---|--|-----------------|--------|
| 156 [0x9C] First channel - minimum brightness level | Defines the minimum brightness level that the light connected to the first channel reaches during dimming. This is a physical change and doesn't alter the Z-Wave command. The value of the minimum brightness level can't be higher than the maximum brightness level, defined by parameter 158. | Range: 1...98 (0x01...0x62) [%] | 20 | 1B |
| 157 [0x9D] Second channel - minimum brightness level | Defines the minimum brightness level that the light connected to the second channel reaches during dimming. This is a physical change and doesn't alter the Z-Wave command. The value of the minimum brightness level can't be higher than the maximum brightness level, defined by parameter 159. | | | |
| 158 [0x9E] First channel - maximum brightness level | Defines the maximum brightness level that the light connected to the first channel reaches during brightening. This is a physical change and doesn't alter the Z-Wave command. The value of the maximum brightness level can't be lower than the minimum brightness level, defined by parameter 156. | Range: 2...99 (0x02...0x63) [%] | 75 | 1B |
| 159 [0x9F] Second channel - maximum brightness level | Defines the maximum brightness level that the light connected to the second channel reaches during brightening. This is a physical change and doesn't alter the Z-Wave command. The value of the maximum brightness level can't be lower than the minimum brightness level, defined by parameter 157. | | | |
| 160 [0xA0] First channel - ON/OFF mode | Necessary when connecting non-dimmable loads. When this mode is activated, the device turns the light source on or off. The dimming function isn't available. | <ul style="list-style-type: none"> • 0 - ON/OFF mode disabled (dimming available) • 1 - ON/OFF mode enable (dimming not available) | 0 | 1B |
| 161 [0xA1] Second channel - ON/OFF mode | | | | |
| 162 [0xA2] First channel - forced level of switching on | Enables setting the brightness level that the lighting should reach when the button assigned to the first channel is clicked once. | Range: 1...99, 255 <ul style="list-style-type: none"> • 255 (0xFF) - The device restores the last non-zero state before the light was switched off • 1-99 (0x01...0x63)[%] - The device switches on the lighting to the maximum level | 255 | 1B |
| 163 [0xA3] Second channel - forced level of switching on | Enables setting the brightness level that the lighting should reach when the button assigned to the second channel is clicked once. | | | 1B |
| 164 [0xA4] First channel - favorite position | Enables setting the brightness level that the lighting should reach when the button assigned to the first channel is clicked twice. | Range: 0...99, 255 <ul style="list-style-type: none"> • 0...99 (0x00...0x63) [%] • 255 (0xFF) - Function disabled | 99 | 1B |
| 165 [0xA5] Second channel - favorite position | Enables setting the brightness level that the lighting should reach when the button assigned to the second channel is clicked twice. | | | |
| 166 [0xA6] Full transition time - hold wall switch control | Defines the time required to complete a full brightening or dimming operation when controlled by holding monostable wall switches. This parameters affects the association of Start Level Change command. | Range: 0...10 <ul style="list-style-type: none"> • 0 - instant reaction • 1...10 (0x01...0x0A) [s] | 5 | 1B |
| 167 [0xA7] Full transition time - radio commands and wall switch click control | Defines the time required to complete a full brightening or dimming operation when controlled with radio commands and clicks from bistable and monostable wall switches. This parameters affects the association of the Switch Multilevel Set command. | | 2 | 1B |
| 200 [0xC8] Voltage measurement | Enables setting the change in voltage value that triggers the device to send a voltage measurement report. If set to "0", the functionality is disabled. | Range: 0, 3...10 <ul style="list-style-type: none"> • 0 - Functionality disabled • 3...10 (0x03...0x0A) [V] | 0 | 1B |
| 201 [0xC9] Voltage value for notification | Enables setting the voltage threshold that the mains voltage must exceed for the device to send a voltage notification report. If set to "0", the functionality is disabled. | Range: 0, 100...260 <ul style="list-style-type: none"> • 0 - Functionality disabled • 100...260 (0x0064...0x0104) [V] | 0 | 2B |
| 202 [0xCA] Outputs (channels) mode | Enables connecting both channels and controlling them simultaneously. When the connected output mode is selected, both channels operate using the settings of the first (master) channel. | <ul style="list-style-type: none"> • 0 - Independent outputs • 1 - Connected outputs | 0 | 1B |

| Table 9 - DoubleDimmer-Control - NIF command class support | | | |
|---|--|----------------|-------------------|
| No. | Command class (CC) | Version | Secure |
| 1. | COMMAND_CLASS_ZWAVEPLUS_INFO [0x5E] | V2 | None |
| 2. | COMMAND_CLASS_SWITCH_MULTILEVEL [0x26] | V4 | Highest Available |
| 3. | COMMAND_CLASS_ASSOCIATION [0x85] | V2 | Highest Available |
| 4. | COMMAND_CLASS_ASSOCIATION_GRP_INFO [0x59] | V3 | Highest Available |
| 5. | COMMAND_CLASS_DEVICE_RESET_LOCALLY [0x5A] | V1 | Highest Available |
| 6. | COMMAND_CLASS_FIRMWARE_UPDATE_MD [0x7A] | V5 | Highest Available |
| 7. | COMMAND_CLASS_INDICATOR [0x87] | V3 | Highest Available |
| 8. | COMMAND_CLASS_MANUFACTURER_SPECIFIC [0x72] | V2 | Highest Available |
| 9. | COMMAND_CLASS_MULTI_CHANNEL_ASSOCIATION [0x8E] | V3 | Highest Available |
| 10. | COMMAND_CLASS_POWERLEVEL [0x73] | V1 | Highest Available |
| 11. | COMMAND_CLASS_SECURITY [0x98] | V1 | None |
| 12. | COMMAND_CLASS_SECURITY_2 [0x9F] | V1 | None |
| 13. | COMMAND_CLASS_SUPERVISION [0x6C] | V1 | None |
| 14. | COMMAND_CLASS_TRANSPORT_SERVICE [0x55] | V2 | None |
| 15. | COMMAND_CLASS_VERSION [0x86] | V3 | Highest Available |
| 16. | COMMAND_CLASS_CONFIGURATION [0x70] | V4 | Highest Available |
| 17. | COMMAND_CLASS_NOTIFICATION [0x71] | V8 | Highest Available |
| 18. | COMMAND_CLASS_CENTRAL_SCENE [0x5B] | V3 | Highest Available |
| 19. | COMMAND_CLASS_METER [0x32] | V5 | Highest Available |
| 20. | COMMAND_CLASS_MULTI_CHANNEL [0x60] | V4 | Highest Available |
| 21. | COMMAND_CLASS_PROTECTION [0x75] | V2 | Highest Available |
| 22. | COMMAND_CLASS_APPLICATION_STATUS [0x22] | V1 | None |
| Command Class – not in NIF | | | |
| 23. | COMMAND_CLASS_BASIC [0x20] | V2 | Highest Available |

| Table 10 - DoubleDimmer-Control - Z-WAVE Plus CC | | |
|---|---------------------|--|
| End Point | Type | Command class (CC) |
| Root Device /End Point 1 | Role Type | (AOEN) ROLE_TYPE_END_NODE_ALWAYS_ON [0x05] |
| | Node Type | NODE_TYPE_ZWAVEPLUS_NODE [0x00] |
| | Installer Icon Type | ICON_TYPE_GENERIC_LIGHT_DIMMER_SWITCH [0x0600] |
| | User Icon Type | ICON_TYPE_GENERIC_LIGHT_DIMMER_SWITCH [0x0600] |
| End Point 2 | Role Type | (AOEN) ROLE_TYPE_END_NODE_ALWAYS_ON [0x05] |
| | Node Type | NODE_TYPE_ZWAVEPLUS_NODE [0x00] |
| | Installer Icon Type | ICON_TYPE_GENERIC_LIGHT_DIMMER_SWITCH [0x0600] |
| | User Icon Type | ICON_TYPE_GENERIC_LIGHT_DIMMER_SWITCH [0x0600] |

Table 11 - DoubleDimmer-Control - Multichannel CC

| Endpoint 1 | |
|----------------------|---|
| Generic Type | GENERIC_TYPE_SWITCH_MULTILEVEL [0x11] |
| Specific Type | SPECIFIC_TYPE_NOT_USED [0x00] |
| Supported CC | COMMAND_CLASS_ZWAVEPLUS_INFO [0x5E] COMMAND_CLASS_SWITCH_MULTILEVEL [0x26] COMMAND_CLASS_ASSOCIATION [0x85] COMMAND_CLASS_ASSOCIATION_GRP_INFO [0x59] COMMAND_CLASS_MULTI_CHANNEL_ASSOCIATION [0x8E] COMMAND_CLASS_SECURITY [0x98] COMMAND_CLASS_SECURITY_2 [0x9F] COMMAND_CLASS_SUPERVISION [0x6C] COMMAND_CLASS_NOTIFICATION [0x71] COMMAND_CLASS_METER [0x32] COMMAND_CLASS_PROTECTION [0x75] COMMAND_CLASS_APPLICATION_STATUS [0x22] |
| Description | Output 1 |
| Endpoint 2 | |
| Generic Type | GENERIC_TYPE_SWITCH_MULTILEVEL [0x11] |
| Specific Type | SPECIFIC_TYPE_NOT_USED [0x00] |
| Supported CC | COMMAND_CLASS_ZWAVEPLUS_INFO [0x5E] COMMAND_CLASS_SWITCH_MULTILEVEL [0x26] COMMAND_CLASS_ASSOCIATION [0x85] COMMAND_CLASS_ASSOCIATION_GRP_INFO [0x59] COMMAND_CLASS_MULTI_CHANNEL_ASSOCIATION [0x8E] COMMAND_CLASS_SECURITY [0x98] COMMAND_CLASS_SECURITY_2 [0x9F] COMMAND_CLASS_SUPERVISION [0x6C] COMMAND_CLASS_NOTIFICATION [0x71] COMMAND_CLASS_METER [0x32] COMMAND_CLASS_PROTECTION [0x75] COMMAND_CLASS_APPLICATION_STATUS [0x22] |
| Description | Output 2 |

Table 12 - DoubleDimmer-Control - Association group information CC

| Group | Profile | Command class & command | Group name |
|-------------------|-----------------------------------|---|------------|
| Root | | | |
| 1 | General: Lifeline (0x00: 0x01) | COMMAND_CLASS_DEVICE_RESET_LOCALLY [0x5A] DEVICE_RESET_LOCALLY_NOTIFICATION [0x01] COMMAND_CLASS_INDICATOR [0x87] INDICATOR_REPORT [0x03] COMMAND_CLASS_SWITCH_MULTILEVEL [0x26] SWITCH_MULTILEVEL_REPORT [0x03] COMMAND_CLASS_NOTIFICATION [0x71] NOTIFICATION_REPORT [0x05] COMMAND_CLASS_CENTRAL_SCENE [0x5B] CENTRAL_SCENE_NOTIFICATION [0x03] COMMAND_CLASS_METER [0x32] METER_REPORT [0x02] COMMAND_CLASS_CONFIGURATION [0x70] CONFIGURATION_REPORT [0x06] | Lifeline |
| 2 | Control: KEY01 (0x20: 0x01) | COMMAND_CLASS_BASIC [0x20] BASIC_SET [0x01] | On/Off S1 |
| 3 | Control: KEY01 (0x20: 0x01) | COMMAND_CLASS_SWITCH_MULTILEVEL [0x26] SWITCH_MULTILEVEL_SET [0x01] COMMAND_CLASS_SWITCH_MULTILEVEL [0x26] SWITCH_MULTILEVEL_START_LEVEL_CHANGE [0x04] COMMAND_CLASS_SWITCH_MULTILEVEL [0x26] SWITCH_MULTILEVEL_STOP_LEVEL_CHANGE [0x05] | Dimmer S1 |
| 4 | Control: KEY02 (0x20: 0x02) | COMMAND_CLASS_BASIC [0x20] BASIC_SET [0x01] | On/Off S2 |
| 5 | Control: KEY02 (0x20: 0x02) | COMMAND_CLASS_SWITCH_MULTILEVEL [0x26] SWITCH_MULTILEVEL_SET [0x01] COMMAND_CLASS_SWITCH_MULTILEVEL [0x26] SWITCH_MULTILEVEL_START_LEVEL_CHANGE [0x04] COMMAND_CLASS_SWITCH_MULTILEVEL [0x26] SWITCH_MULTILEVEL_STOP_LEVEL_CHANGE [0x05] | Dimmer S2 |
| Endpoint 1 | | | |
| 1 | General: Lifeline (0x00: 0x01) | COMMAND_CLASS_SWITCH_MULTILEVEL [0x26] SWITCH_MULTILEVEL_REPORT [0x03] COMMAND_CLASS_METER [0x32] METER_REPORT [0x02] COMMAND_CLASS_NOTIFICATION [0x71] NOTIFICATION_REPORT [0x05] | Lifeline |
| 2 | Control: KEY01 (0x20: 0x01) | COMMAND_CLASS_BASIC [0x20] BASIC_SET [0x01] | On/Off S1 |
| 3 | Control: KEY01 (0x20: 0x01) | COMMAND_CLASS_SWITCH_MULTILEVEL [0x26] SWITCH_MULTILEVEL_SET [0x01] COMMAND_CLASS_SWITCH_MULTILEVEL [0x26] SWITCH_MULTILEVEL_START_LEVEL_CHANGE [0x04] COMMAND_CLASS_SWITCH_MULTILEVEL [0x26] SWITCH_MULTILEVEL_STOP_LEVEL_CHANGE [0x05] | Dimmer S1 |
| Endpoint 2 | | | |
| 1 | General: Lifeline (0x00: 0x01) | COMMAND_CLASS_SWITCH_MULTILEVEL [0x26] SWITCH_MULTILEVEL_REPORT [0x03] COMMAND_CLASS_METER [0x32] METER_REPORT [0x02] COMMAND_CLASS_NOTIFICATION [0x71] NOTIFICATION_REPORT [0x05] | Lifeline |
| 2 | Control: KEY02 (0x20: 0x02) | COMMAND_CLASS_BASIC [0x20] BASIC_SET [0x01] | On/Off S2 |
| 3 | Control: KEY02 (0x20: 0x02) | COMMAND_CLASS_SWITCH_MULTILEVEL [0x26] SWITCH_MULTILEVEL_SET [0x01] COMMAND_CLASS_SWITCH_MULTILEVEL [0x26] SWITCH_MULTILEVEL_START_LEVEL_CHANGE [0x04] COMMAND_CLASS_SWITCH_MULTILEVEL [0x26] SWITCH_MULTILEVEL_STOP_LEVEL_CHANGE [0x05] | Dimmer S2 |

Table 13 - DoubleDimmer-Control - Association CC/Multichannel association CC

| Group | Max nodes supported | Comment |
|--------------------|---------------------|-----------|
| Root Device | | |
| 1 | 1 | Lifeline |
| 2 | 5 | On/Off S1 |
| 3 | 5 | Dimmer S1 |
| 4 | 5 | On/Off S2 |
| 5 | 5 | Dimmer S2 |
| Endpoint 1 | | |
| 1 | 0 | Lifeline |
| 2 | 5 | On/Off S1 |
| 3 | 5 | Dimmer S1 |
| Endpoint 2 | | |
| 1 | 0 | Lifeline |
| 2 | 5 | On/Off S2 |
| 3 | 5 | Dimmer S2 |

Table 14 - DoubleDimmer-Control - Switch multilevel CC

| Command | Value | State | Description |
|-------------------------------|------------------|---------------|-------------|
| Root Device/Endpoint 1 | | | |
| SET/REPORT | 0 (0x00) | 0% | Output1 |
| SET/REPORT | 1-99 (0x01-0x63) | 1-99% | Output 1 |
| SET | 0x64..0xFE | reserved | Output 1 |
| SET | 255 (0xFF) | Last ON value | Output 1 |
| Endpoint 2 | | | |
| SET/REPORT | 0 (0x00) | 0% | Output 2 |
| SET/REPORT | 1-99 (0x01-0x63) | 1-99% | Output 2 |
| SET | 0x64..0xFE | reserved | Output 2 |
| SET | 255 (0xFF) | Last ON value | Output 2 |

Table 15 - DoubleDimmer-Control - Basic CC

| Command | Root map EP | Mapping (Endpoints) | |
|---------------------|-------------|---------------------------------|---------------------------------|
| | | 1 | 2 |
| Basic Set | 1 | SWITCH_MULTILEVEL_SET [0x01] | SWITCH_MULTILEVEL_SET [0x01] |
| Basic Get | 1 | SWITCH_MULTILEVEL_GET [0x02] | SWITCH_MULTILEVEL_GET [0x02] |
| Basic Report | 1 | SWITCH_MULTILEVEL_REPORT [0x03] | SWITCH_MULTILEVEL_REPORT [0x03] |

Table 16 - DoubleDimmer-Control - Indicator CC

| Root | | | |
|---|--------------|-------------------------------|-------------|
| Indicator ID Node Identify [0x50] | | | |
| Property ID On/Off Period [0x03] On/Off Cycles [0x04] One time On/Off period [0x05] | | | |
| Command | Indicator ID | Property ID | Value |
| SET | All | On/Off Period [0x03] | 0x00 – 0xFF |
| SET | All | On/Off Cycles [0x04] | 0x00 – 0xFF |
| SET | All | One time On/Off period [0x05] | 0x00 – 0xFF |
| GET | All | - | - |

Table 17 - DoubleDimmer-Control - Meter CC

| Meter type | Scale | Rate type | Precision | Size |
|-----------------|---------------------|---------------|-----------|------|
| Root/Endpoint 1 | | | | |
| Electric [0x01] | Electric_V [0x04] | Import [0x01] | 0 | 4 |
| Electric [0x01] | Electric_W [0x02] | Import [0x01] | 1 | 4 |
| Electric [0x01] | Electric_kWh [0x00] | Import [0x01] | 2 | 4 |
| Endpoint 2 | | | | |
| Electric [0x01] | Electric_W [0x02] | Import [0x01] | 1 | 4 |
| Electric [0x01] | Electric_kWh [0x00] | Import [0x01] | 2 | 4 |

Table 18 - DoubleDimmer-Control - Protection CC

| Type | State | Description |
|----------------------------|----------------------|---|
| Root/Endpoint 1/Endpoint 2 | | |
| Local | Unprotected [0x00] | The device isn't protected, and can be operated normally with the user interface (buttons). |
| Local | No operation [0x02] | Buttons (S1 or S2) can't change state, other functionalities, such as menu, are available. |
| RF | Unprotected [0x00] | The device accepts and responds to all RF commands. |
| RF | No RF control [0x01] | Command Class Basic and actuator command class are rejected, other command classes are handled. |

Note

Protection CC State can be set independently on each endpoint.

Table 19 - DoubleDimmer-Control - Notification CC

| Notification type | Event /State | Event /State parameter | Status (default) |
|--------------------------|---|-----------------------------------|--------------------------------|
| Root / Endpoint 1 | | | |
| System [0x09] | System hardware failure (manufacturer proprietary failure code provided) [0x03] | MP code: 0x01 [device overheat] | 0xFF – enable (not changeable) |
| Power Management [0x08] | Voltage drop/drift [0x05] | - | 0xFF – enable (not changeable) |
| Power Management [0x08] | Over-current detected [0x06] | | 0xFF – enable (not changeable) |
| Power Management [0x08] | Load error [0x09] | - | 0xFF – enable (not changeable) |
| Power Management [0x08] | Over-voltage detected [0x07] | - | 0xFF – enable (not changeable) |
| System [0x09] | System hardware failure (manufacturer proprietary failure code provided) [0x03] | MP code: 0x06 [Hardware fail] | 0xFF – enable (not changeable) |
| System [0x09] | System hardware failure (manufacturer proprietary failure code provided) [0x03] | MP code: 0x07 [Non-dimmable load] | 0xFF – enable (not changeable) |
| Endpoint 2 | | | |
| Power Management [0x08] | Over-current detected [0x06] | - | 0xFF – enable (not changeable) |
| Power Management [0x08] | Load error [0x09] | - | 0xFF – enable (not changeable) |
| System [0x09] | System hardware failure (manufacturer proprietary failure code provided) [0x03] | MP code: 0x07 [Non-dimmable load] | 0xFF – enable (not changeable) |

Note

If the voltage level is restored below the notification tripping threshold, after ten minutes the device sends a notification cancellation.

14 REGULATIONS

Legal Notices:

All information, including, but not limited to, information regarding the features, functionality, and/or other product specification are subject to change without a notice. NICE reserves all rights to revise or update its products, software, or documentation without any obligation to notify any individual or entity.

NICE logo is a trademark of NICE SpA Oderzo TV Italia. All other brands and product names referred to herein are trademarks of their respective holders.

Declaration of conformity



Hereby, NICE SpA Oderzo TV Italia declares that DoubleDimmer-Control is in compliance with the essential requirements and other relevant provisions of Directive 2014/53/EU. The full text of the EU declaration of conformity is available at the following internet address: www.niceforyou.com/en/download?v=18

WEEE Directive Compliance



Device labelled with this symbol shouldn't be disposed with other household wastes. It shall be handed over to the applicable collection point for the recycling of waste electrical and electronic equipment.



Nice SpA
Oderzo TV Italia
info@niceforyou.com

www.niceforyou.com

IS0975A001MMD_01-09-2025